

RENOLIT INDUSTRIAL GREASES

Grades, applications, terminology, tests



RENOLIT industrial greases make up a comprehensive and balanced program of products which not only offers optimum technical but also economic solutions for the largest possible number of industrial applications.

This brochure contains excerpts of the FUCHS industrial grease program.

In addition, the brochure also contains important information on applications, terminology and the testing of greases.

Special greases and specific customer formulations are available on request.

The following criteria need to be considered when selecting a grease:

| Operating temperature

| Load

| RPM and speed

| Ambient conditions (water, dust, acids, alkalines, etc.)

| Sealing materials and plastics.

Together with leading manufacturers of central lubrication systems, we can also offer customers perfect grease application solutions.

Content	Page
Introduction	1
A. Core program	2-5
1. Greases, water-resistant, up to +60 °C	2-3
2. Greases, not water-resistant, up to +120 °C	2-3
3. Multipurpose greases for temperatures up to +120 °C	2-3
4. Greases for temperatures > +120 °C and high loads	4-5
B. Specialties	6-21
1. Greases containing solid lubricants	6-7
2. Semi-fluid greases for central lubrication systems and gearboxes	8-9
3. Heavy duty greases	10-11
4. Special greases	12-15
5. Food grade greases	16-17
6. Rapidly biodegradable greases	16-17
7. Silicone greases	18-19
8. Spray cans	20-21
C. Terminology and tests	22-26

Product name	Classification DIN 51 502 ISO 6743-9 Solid lubricant	Colour	Product information	Thickener Base oil	NLGI- grade	Dropping point [°C]	Operating temperature																Remarks Application area																	
							Minus								Plus																									
							= continuous																= short term																	
							70	60	50	40	30	20	60	80	100	120	140	160	180	200	220	240	260	280																

7. Silicone greases

RENOLIT SI 300 M Also in NLGI grade 3 (S) and as bridge bearing lubricant available.	KSI 2 P-70 ISO-L-X-EEHA 2	white	5-6040	Lithium soap Silicone oil	2	>210																	Low temperature grease for electrical and precision machinery, sealing grease for radial seals, O-rings, bellows. Approvals: DBL 6812.10 and VW TL 767 X.
RENOLIT SI 400 M Also in NLGI grade 1 (L) available.	KSI 2 R-30 ISO-L-X-EFEA 2	white	5-6060	Lithium soap Silicone oil	2	>210																	Standard silicone grease for light to averagely loaded plain and roller bearings, electric motors, guides, household equipments, fans and dryers.
RENOLIT SI 410 M	KSI 2 K-55 ISO-L-X-ECEA 2	white transparent	5-6080	Calcium soap Silicone oil	2	>140																	Beer tap grease, for the greasing of taps, bearings and seals in brewing and filling lines of the beverage industry, food processing and packaging machines. Approvals: NSF-H2, KTW.
RENOLIT SI 511 M Also in NLGI grade 1 (L) and 00 (F) available.	KSI 2 T-30 ISO-L-X-CGEA 2	light brown	5-6078	Polyurea Silicone oil	2	>300																	High-temperature grease for plain and roller bearings, assembly lubricant for rubber and plastics, applications also in the textile industry, brickworks, casting shops, paper mills, e.g. in hot air ventilators, drying ovens, electric motors, conveyor systems, kiln cars. For the following bearing materials: metal/metal, metal/plastic and plastic/plastic.
RENOLIT SI 704 Also in NLGI grade 2/1 (703) and 4 (708) available.		colourless transparent	5-6015	HDK Silicone oil	3	none																	Assembly aid for organic elastomers and plastics, sealant for elastomers, for electronic and chemical equipment, e.g. plastic chains, joints, control units, threaded connections. For the following material combinations: metal/plastic and plastic/plastic.
RENOLIT SI HVS	MSI 3 S-40 ISO-L-X-DGHA 3	colourless transparent	5-6090	HDK Silicone oil	3	none																	High vacuum grease with a low evaporation loss for lubrication and sealing of check valves and glass joints, which work in the range from 10 ⁻³ to 10 ⁻⁸ mbar; highly-adhesive and good sealing properties.
RENOLIT SILICONE WRAS	MSI 3 S-40 ISO-L-X-DGIA 3	white	5-6000	PTFE Silicone oil	3	none																	Highly water repellent, tasteless and odourless grease. Especially formulated for the lubrication of taps, valves, mixer, tap ceramic discs and spindles as well as threaded stainless steel components. Approvals: KTW and WRAS.

HDK = Highly dispersed silic acid

Product name	Remarks Application area	Benefits
--------------	-----------------------------	----------

8. Spray cans

RENOLIT UNIMAX LZ Basis: RENOLIT CA-LZ	Long-life tacky grease for lubrication of plain and roller bearings, chains and gears in the construction machinery and agricultural industry, for cars, motorbikes, household and the hobby area.	MAXimum tackiness, resistant to salt water, good lubrication properties and long fibrous.
RENOLIT UNIFOOD Basis: RENOLIT G 7 FG 1	Special grease for plain and roller bearings of packaging and filling machines in the food industry.	Excellent lubrication properties, conform to the requirements of NSF-H1 and KTW, odourless and tasteless.
RENOLIT UNILOAD Basis: RENOLIT CX-HT 2	High temperature grease for low speeds and mechanically highly-stressed plain and roller bearings, especially when excellent corrosion and wear protection is necessary, lubrication of open gears.	Extremely tacky, thermally stable, extreme EP loadable, excellent corrosion protection even in the presence of salt water, offers emergency running properties.
RENAX GLEITSPRAY Basis: RENOLIT GL 1	Special grease for lubrication in the industry, of cars, at home or for hobbies, ideal assembly lubricant.	Excellent reduction of friction and wear, long life lubrication, adhesive, noise damping, temperature stable, synthetic grease.
PLANTO MULTISPRAY Basis: PLANTOGEL 2 S	Environmentally friendly grease for the construction and agriculture industry, household, garden and hobby.	Environmentally friendly, because it is rapidly biodegradable. Good lubrication properties, high anti-wear and corrosion protection.
DUOTAC CP 300	Special-tacky grease for chains, threads and bolts, open gears, steel cables and slide bars.	Free of bitumen, contains graphite, high mechanical resistance, high adhesiveness, grease like lubricating film.
DUOTAC ZAHNRADSPRAY	Special grease for chains, gear racks, gear rims and gears, e.g. fork lift trucks, construction and agriculture machines.	Free of bitumen, contains graphite, high mechanical resistance, extremely tacky, resistant to hot and salt water, dry and bendable lubricating film.

C. Terminology and tests

Introduction

Greases are firm lubricants consisting of base oils and specially selected thickeners. Additives are also added to greases to improve certain characteristics.



Greases are engineering elements, especially long-life lubricants

For a number of applications, lubricating with grease offers the advantage of offering a barrier between the sliding surfaces, thus reducing friction, wear and increasing efficiency. Compared to oils, greases have a series of benefits:

- Lower maintenance input
- Lubrication for life is possible
- Simpler seal designs
- Lower engineering complexity
- Lower leakage hazard
- The formation of a grease lip supports the sealing effect of seals

Just a few grams of grease can protect against high repair bills and the surprisingly expensive follow-up costs caused, for example, by machine down-times. It is therefore prudent to pay

Table 1: Prefix letters and symbols for greases (colour: white)

1	2	3
Type of grease	Prefix letter	Symbol
Greases for roller bearings, plain bearings and sliding surfaces, defined by DIN 51 825	K ¹⁾	For mineral oil-based greases 
Greases for enclosed gears defined by DIN 51 826	G	
Greases for open gearboxes and exposed gears (bitumen-free tacky lubricants)	OG	
Greases for plain bearings and seals ²⁾	M	For synthetic greases 
The basic characteristics of synthetic greases are classified similarly to mineral oil-based products	Add the letter from Table 1, substance groupe 3	

¹⁾ ISO/TR 3498 : 1986 the letters XM are used instead of K
²⁾ Lower requirements than for K-type greases

Table 2. NLGI grades

NLGI grade	Worked penetration in 0.1 mm DIN ISO 2137	Description
000	445 / 475	Flowing
00	400 / 430	Flowing
0	355 / 385	Still flowing
1	310 / 340	Very soft
2	265 / 295	Soft-creamy
3	220 / 250	Still soft
4	175 / 205	Moderately stiff
5	130 / 160	Stiff
6	85 / 115	Very stiff

special attention to greases.

1. Classification and allocation of K-type greases according to DIN 51 502

Due to the vast number of possible applications and their differing compositions, greases are classified and grouped according to certain parameters. DIN 51 502 describes the following classification:

Classification and characteristics of a K-type grease

Grease DIN 51 502 – K 1 G-20

Name
DIN standard number
Letter denoting type of grease (see Table 1)
Consistency (NLGI grade, see Table 2)
Additional letter (see Table 3)
Additional number (see Table 4)

Description of a K-type grease, of NLGI grade 1 (see Table 2), additional letter G (see Table 3) and additional number –20 (see Table 4).

Table 3: Additional code letters for greases

1	2	3
Letter	Max operating temperature ¹⁾	Water resistance, defined by DIN 51 807-1; evaluation stage DIN 51 807 ²⁾
C	+60 °C	0-40 or 1-40
D		2-40 or 3-40
E	+80 °C	0-40 or 1-40
F		2-40 or 3-40
G	+100 °C	0-90 or 1-90
H		2-90 or 3-90
K	+120 °C	0-90 or 1-90
M		2-90 or 3-90
N	+140 °C	Subject to agreement
P	+160 °C	
R	+180 °C	
S	+200 °C	
T	+220 °C	
U	over +240 °C	

¹⁾ Max operating temperature for lubricated-for-life applications is the highest temperature tested by DIN 51 821-2 insofar as the test is passed.

²⁾ 0 = denotes no change
1 = denotes small change
2 = denotes moderate change
3 = denotes great change

Table 4: Additional numbers for greases

1	2
Additional number	Minimum operating temperature
-10	-10 °C
-20	-20 °C
-30	-30 °C
-40	-40 °C
-50	-50 °C
-60	-60 °C

2. Cone penetration, as defined by DIN ISO 2137

Penetration in this case is the depth, measured to an accuracy of 0.1 mm, to which a standard cone sinks into the grease in defined conditions. For example, 26.5 mm penetration is 265 x 0.1 mm

In general, greases which have been mechanically worked become some-what softer; therefore there is a difference between – Unworked penetration P_u and – Worked penetration P_w

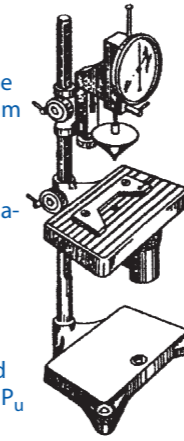

3. Worked penetration, as defined by DIN ISO 2137

Prior to this penetration test, the grease is mechanically churned:

- $P_{w60} = 60$ double strokes
- $P_{w10^5} = 1 \times 10^5$ double strokes

Worked penetration results form the basis of NLGI grades

4. Consistency, as defined by DIN 51 818

Consistency, as shown by NLGI grade, is based on worked penetration figures (see Table 2).

5. Consistency stability

Consistency stability is the resistance of a grease to the mechanical shearing of the soap thickener

An indication of consistency stability is the worked stability
– Worked stability = $P_w - P_u$
– The smaller the difference, the better the consistency stability of the grease

6. Base oil

95% of greases are based on mineral base oils. The rest are based on synthetic oils like polyalphaolefins, natural and synthetic esters, glycols, polyethers, silicone oils and other products.

Depending on the type of thickener used and the desired consistency of the finished grease, between 65% and 95% of the grease is base oil, the rest thickener and additives.

The type of base oil and its viscosity are of fundamental significance to certain basic properties of greases.

Working temperature, pumpability, EP performance, ageing stability, elastomer compatibility, tackiness, oil separation and noise suppression are just a few of the characteristics of a grease which are directly determined or influenced by the base oil.

7. Thickeners

Thickeners are divided into soap and non-soap versions and these products also influence basic properties of a grease such as temperature range, water resistance and EP performance. Soap thickeners are divided into simple and complex versions which, due to their higher dropping point, allow an increase in the upper temperature limit. The following thickeners are used in FUCHS greases:

Simple and complex soap thickeners

Lithium
Calcium
Aluminium
Sodium

Non-soap thickeners

Bentonite
Highly dispersed silicic acid
Polyurea
PTFE

8. Additives

Additives are included in greases to achieve certain characteristics. A grease can contain up to 10% additives. Above all, the following additives are used:

- | | |
|----------------------------------|------------------------------------|
| Extreme pressure (EP) additives: | to improve load carrying behaviour |
| Anti-wear (AW) additives: | to protect against wear |
| Corrosion protection additives: | to avoid corrosion |
| Anti-Oxidation (AO) additives: | to improve ageing stability |
| Tackiness improvers: | to increase the tackiness |
| Solid lubricants: | to provide run-dry lubrication |

9. Service temperature range

All greases have a working temperature range in which the grease can develop all the characteristics it claims to offer.

The temperature range of a grease is determined by test methods and practical trials.

10. Ageing

Greases generally age as a result of oxidation processes, i.e. reactions with the oxygen in the air. A critical factor is the temperature range in which the grease will be used. Ageing is accelerated by high temperatures.

11. Miscibility of greases

The question of the miscibility of different greases often arises when re-lubricating operations are performed. Not all greases are compatible with each other. Greases containing the same thickener and the same type of base oil are usually compatible. However, as this compatibility also depends on the additives in the grease, this cannot be taken for granted. Mixing non-compatible greases generally leads to a decrease in the dropping point and a hardening or softening of the grease.

As a rule therefore, mixing greases should be avoided. A much better option is to clean the bearing and to refill with a fresh product. If this is not possible, contact should be made with a FUCHS application engineer before a bearing is re-lubricated.

12. Compatibility with elastomers and plastics

The compatibility of lubricants with elastomers and plastics cannot be definitively answered because of the huge number of materials which exist. One can assume that mineral oils are commonly compatible with NBR elastomers but the compatibility of every additive cannot be taken from lists. At the same time, some synthetic greases attack thermoplastics while mineral oils are relatively unproblematic with these products

The effect of inadequate compatibility of an elastomer or plastic with a grease can be unacceptable shrinking or swelling, a large change to Shore A hardness or even rupturing.

A lot of experience has been gathered with a number of material/lubricant combinations. We have performed compatibility tests on most of our greases with SRE-NBR 1. Seal manufacturers use these results to evaluate their materials. In the case of untested material/grease combinations, it is recommended that realistic tests are performed by the seal manufacturers.

Elastomer Compatibility index (ECI)

The Elastomer Compatibility Index is a reliable method of numerically describing the effect of lubrications on representative standard reference elastomers as defined in ISO 6072 and DIN 53 538. The ECI is based on changes to the volume, hardness, elongation and tensile strength of a standard reference elastomer caused by the influence of the lubricant in controlled conditions. The volume change of a standard reference elastomer is linearly proportional to the swelling behaviour of commonly used elastomers so that the volume change of a standard reference elastomer caused by a lubricating oil or grease can be extrapolated to any elastomer in question, thus eliminating the need to perform individual swelling tests. Corresponding information is available from the elastomer manufacturers.

13. Kesternich flow pressure, as defined by DIN 51 805

Flow pressure is the pressure necessary to force grease through a defined nozzle. This figure provides information about the consistency of a grease in relation to low temperatures.

The temperature generated by a flow pressure of 1400 hPa is also the lower operating temperature of a grease.

14. FAG FE9 roller bearing test rig, defined by DIN 51 821-1 and -2.

A practical procedure to determine the life of greases in roller bearings

Test bodies: 5 FAG tapered rollers

Axial load: 1500, 3000 and 6000 N

RPM: 3000 and 6000 rpm

Test temperature: Up to +250 °C

Test criteria: F_{10} and F_{50} in hours

The test temperature, over 100 hours for the F_{50} value, is also the upper temperature limit of K-type greases as defined by DIN 51 825.

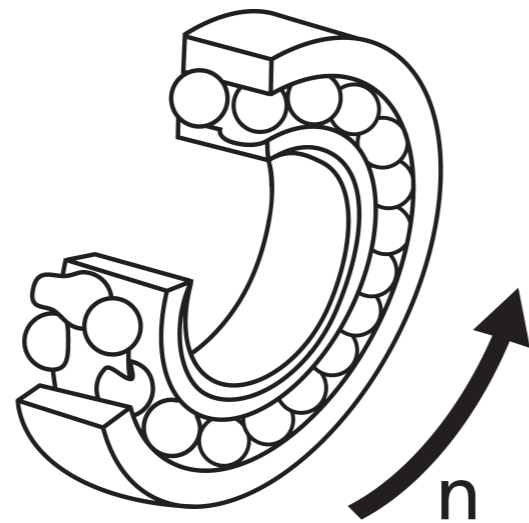

15. EMCOR corrosion protection, as defined by DIN 51 802

Testing the corrosion inhibiting properties of lubricants in realistic, practical conditions

- 2 roller bearings 1306 K
- 7 day cycle (8 hours running – 16 hours stationary)
- $n = 80$ rpm
- distilled water
- or distilled water with 3% NaCl
- evaluation criterion is the degree of corrosion on the outer race

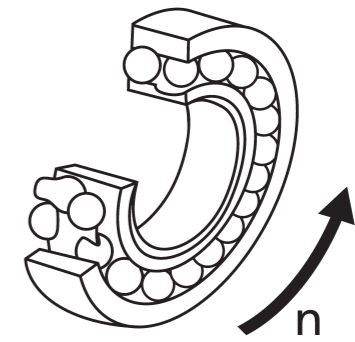

Degree of corrosion	Description	Description of the surface
0	No corrosion	Unchanged
1	Traces of corrosion	Max. 3 spots < 1 mm
2	Slight corrosion	less than 1% of the surface area
3	Moderate corrosion	more than 1% to less than 5%
4	Heavy corrosion	more than 5% to less than 10%
5	Serious corrosion	more than 10% of the surface area

16. Determining oil separation by DIN 51 817

This static method can assist determining the oil separation of greases during their storage. This information cannot be used to quantify the lubricity of a grease.

The grease-filled test apparatus is loaded with a 100-gram weight.

Test duration: 18 hours or 7 days

Test temperature: +40 °C

Test criterion: Quantity of oil separated in %

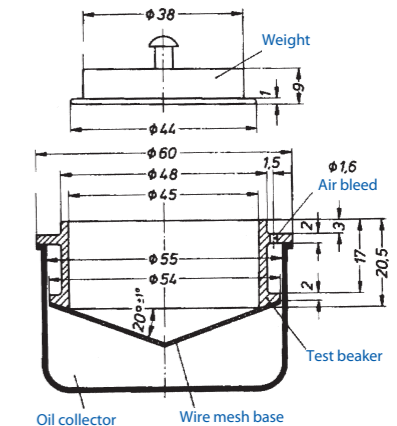

Oil often collects at the surface, especially in hollows of grease and at the bottom of grease containers. This is a typical phenomenon of the grease. It represents no deterioration of grease quality.

Any such oil can be mixed back into the grease with suitable paddles.

17. Dropping point, as defined by DIN ISO 2176

The dropping point is the temperature at which, in defined conditions, the three dimensional grease structure is melting, i.e. it drops out of the test cup.

The dropping point of a grease is only of limited significance to the practical behaviour of a grease.

The dropping point can be determined by automatic method IP 396 or by hand method DIN ISO 2176.

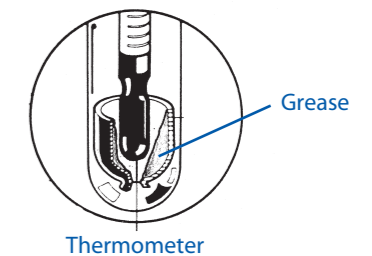

18. Water resistance – Static test as defined by DIN 51 807-1

This static procedure should illustrate how a grease behaves when exposed to distilled water.

Test medium: Distilled water

Test object: Grease on glass strips

Test duration: 3 hours

Test criterion: Optical changes

Evaluation stages: 0 to 3, along with temperature, e. g. 0–40 or 0–90

Evaluation level	Indicates	Description
0	No change	None of the changes listed below
1	Slight change	Colour change (lightening) to the surface of the grease, caused by a marginal absorption of moisture into the upper surface of the grease
2	Moderate change	Grease starts to dissolve, indicated by the formation of a yellowish-whitish slimy layer on the grease and moderate to major turbidity in the water
3	Major change the formation of a milky-white oil-in-water emulsion	Partial to total dissolution of the grease along with oil separation and

19. Copper corrosion, as defined by DIN 51 811

This test procedure serves to determine whether a grease corrodes copper.

Test medium: Grease

Test object: Copper strips

Test duration: 24 hours

Test criterion: Degree of corrosion based on discolouration

Evaluation stages: 1 to 4, along with temperature, e.g. 1-100

Degree of corrosion	Indicates	Description
1	Slight discolouration	Weak orange, freshly ground copper colour, to dark orange
2	Moderate discolouration	Wine red, lavender blue, multi-coloured with lavender blue and/or silvery gloss
3	Major discolouration	Magenta-coloured layer with a reddish, greenish hue (peacock-like) but not grey
4	Corrosion	Translucent black, dark grey or brown a slight hue, graphite black or mat black

20. Determining oxidation stability, as defined by DIN 51 808

The oxidation stability of a grease indicates its resistance to the effects of oxygen in static conditions. A grease sample is exposed to oxygen under pressure.

Any pressure drop is a measure of oxidation stability. The lower the pressure drop, the greater the oxidation stability of the grease.

In normal circumstances the test is performed for 100 hours at 100 °C.

In the case of a good grease, the pressure drop is less than 0.5 bar.

22. Storage/use

As opposed to foodstuffs, greases are not perishable. As a result, greases do not have "best-by" date restrictions.

Greases can be stored for years!

When in reasonable conditions and in original containers, FUCHS RENOLIT industrial greases can be stored for, at least, the following periods:

Rapeseed oil-based greases	2 years
Mineral and synthetic oil-based greases	3 years

21. Four Ball Apparatus test, as defined by DIN 51 350

This procedure, for lubricants with EP-additives, tests the wear behaviour in boundary friction conditions.

Test medium: Four bearing balls

Rotational speed: 1420 rpm

Load: 150 to 12000 N

Test duration: 1 minute or 1 hour

Test criterion: Welding load (N) and scardiameter (mm)

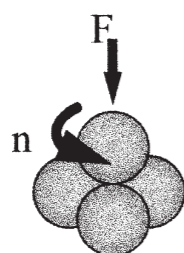

Greases which achieve a welding load of 2000 N or above are described as EP greases.

Notes:

Please contact:

FUCHS EUROPE SCHMIERSTOFFE GMBH
Friesenheimer Straße 15
68169 Mannheim / Germany
Phone: +49 621 3701-0
Fax: +49 621 3701-570
E-mail: zentrale@fuchs-europe.de
www.fuchs-europe.de