

Product range
Special lubricants for Wind Power Plants



A golden globe with a blue shadow, symbolizing global reach. The globe is composed of splashing golden liquid, with a blue shadow cast below it. The background is a light blue gradient.

OPTIMUM SOLUTIONS – WORLDWIDE

The two affiliates FUCHS SCHMIERSTOFFE and FUCHS LUBRITECH offer their combined expertise in the field of wind power. Both companies are wholly owned subsidiaries of FUCHS PETROLUB SE, the world's largest independent lubricant manufacturer. They offer their customers a wide range of high-performance lubricants and greases, as well as hydraulic and gear oils. The worldwide network of the FUCHS Group secures availability of the lubricants worldwide – including consulting, logistics and aftersales service.

FUCHS has the expertise to solve all lubrication-based challenges faced by wind turbine manufacturers, drive component manufacturers and also wind farm operators. No matter what lubrication tasks need to be performed in a wind turbine, FUCHS can provide exactly the right lubricant.

Two strong partners – one team



Headquarter of
FUCHS LUBRITECH in Kaiserslautern

Within the FUCHS Group, LUBRITECH is the expert for highly specialized applications. With its headquarters in Kaiserslautern, Germany and more than 500 employees worldwide, the company develops, produces and markets more than 1,000 special products, each of which is tailored precisely to its respective applications. The focus is on niche applications with maximum lubricant performance requirements and on providing outstanding technical consulting services by our lubricant experts.



Sales and technology centre of
FUCHS SCHMIERSTOFFE GMBH in Mannheim

FUCHS SCHMIERSTOFFE GMBH is a German company with more than 800 employees that manufactures and markets lubricants and related specialties.

The company, founded in 1931 as RUDOLF FUCHS, has its HQ in Mannheim and operates four facilities in Germany. Its degree of specialization and speed of innovation is far above the average for this industry. The product portfolio includes almost 2,000 lubricants and related specialties for all walks of life, industrial processes and applications.



LUBRITECH
Special Application Lubricants



Application areas

FUCHS offers a broad product portfolio of special lubricants for all wind power applications. Many approvals of turbine, gearbox and bearing manufacturers as well as suppliers of filtering systems prove the high performance and quality of our products.

	Lubricant application	Lubricants
1	Pitch adjustment bearing	GLEITMO 585 K STABYL EOS E 2 STABYL LX 460 SYN
	Tooth system	CEPLATTYN BL WHITE CEPLATTYN BL GLEITMO 585 K STABYL LX 460 SYN
2	Rotor bearing	STABYL LX 460 SYN STABYL EOS E2
3	Clutch	GLEITMO 585 K STABYL EOS E 2 STABYL LX 460 SYN
4	Main gearbox	RENOLIN UNISYN CLP 320 RENOLIN UNISYN XT 320 GEARMASTER ECO 320 RENOLIN PENTOGEAR 320 WT RENOLIN PG 320 RENOLIN CLP 320
5	Generator bearings	URETHYN XHD 2
6	Yaw system reduction gear (azimuth)	GEARMASTER ECO 220 RENOLIN UNISYN CLP 220 RENOLIN UNISYN XT 220 RENOLIN PG 220 RENOLIN CLP 220
7	Yaw system: Bearing	GLEITMO 585 K STABYL EOS E 2 STABYL LX 460 SYN
	Tooth system	CEPLATTYN BL WHITE CEPLATTYN BL GLEITMO 585 K STABYL LX 460 SYN STABYL EOS E 2
8	Hydraulic systems	ECO HYD Plus RENOLIN UNISYN OL 32, 46 RENOLIN XtremeTemp 32, 46 RENOLIN ZAF 32 LT
	Sprocket, roller bearing	GLEITMO WSP 5040
	Slip ring cleaner	Rivolta S.L.X. Top
	Fasteners/assembly aids	FERROFORM LOCC FERROFORM ECO LOCC
	Rapid rust removers	ANTICORIT CPX DECORDYN HF 91 DECORDYN 350
	Waxy rust-preventive	CEPLATTYN 300



5
Generator bearings

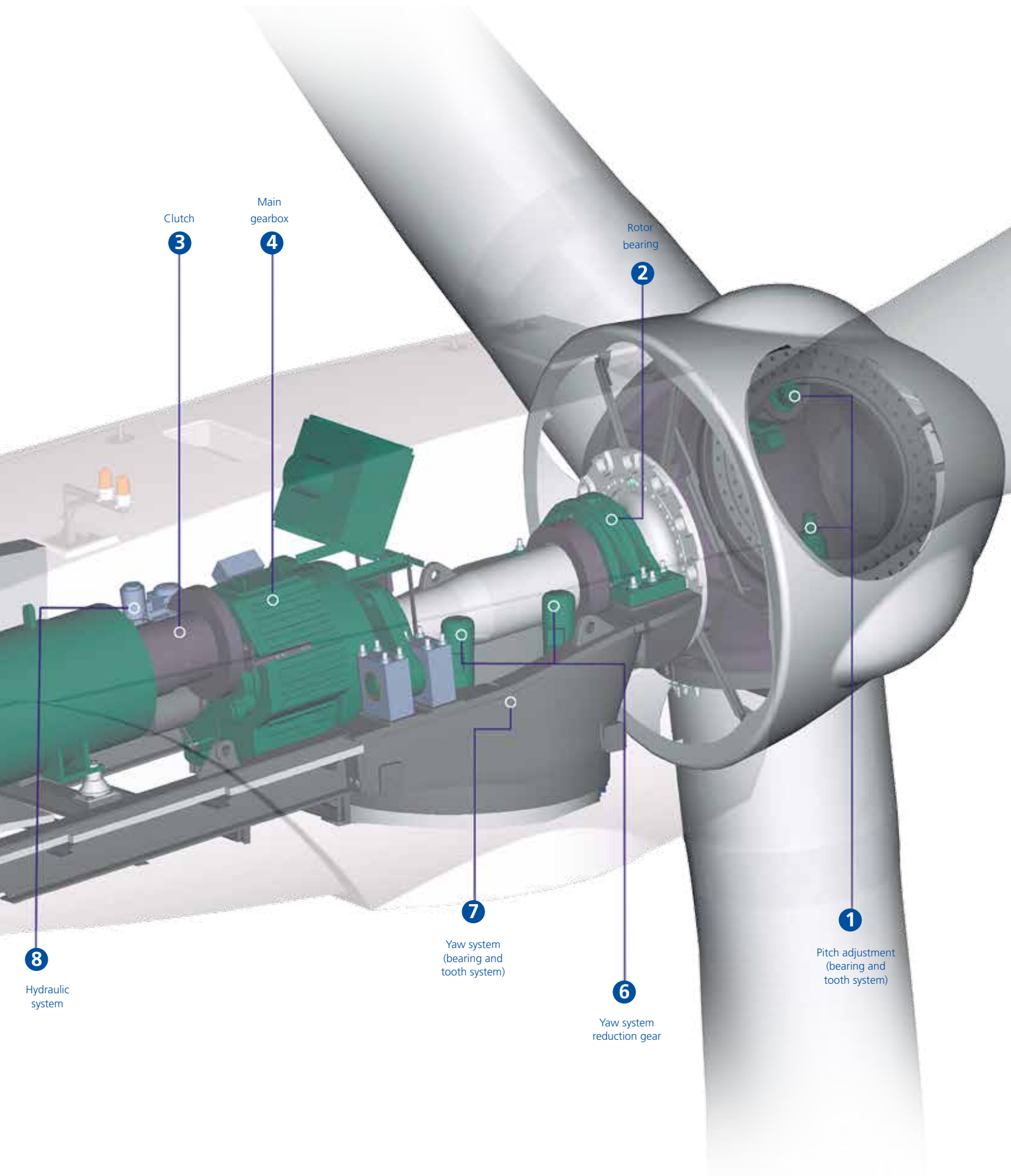

3 Clutch

4 Main gearbox

2 Rotor bearing

1

Pitch adjustment (bearing and tooth system)

6

Yaw system reduction gear

7

Yaw system (bearing and tooth system)

8

Hydraulic system

FUCHS LUBRITECH – SPECIALTY LUBRICANTS FOR THE WIND INDUSTRY

Whether in hot, cold, dry, or “aggressive” saline environments – wherever wind power stations generate energy, we do everything to ensure that no energy is lost unnecessarily. We have developed specialty lubricants for this purpose which clearly contribute to reducing the wear on your equipment and thus significantly reduce your maintenance effort and expenditures. We offer low-temperature greases for arctic conditions, high-performance greases for long-term lubrication, or efficient specialty lubricants for pitch and yaw bearings – all for ideally smooth generation of energy with no loss of energy and with optimal frictional wear protection.

Special lubricant for pitch and yaw bearings (gearing and bearing)

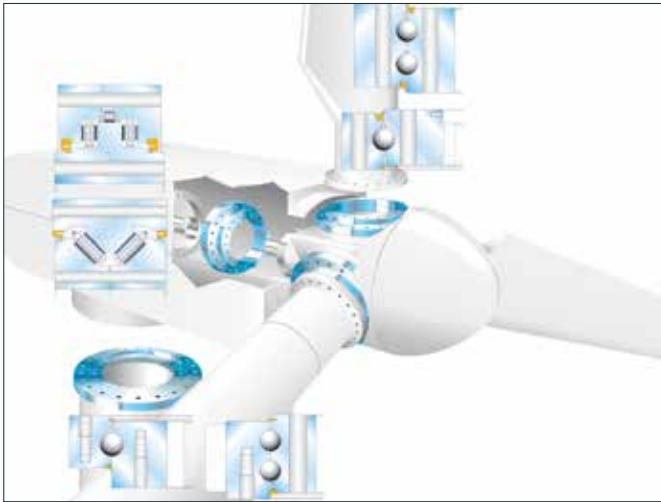

Photo: Rothe Erde

GLEITMO 585 K

GLEITMO 585 K is a fully-synthetic special lubricant containing synergistic reactive white solid lubricants. This combination offers excellent protection against wear especially under critical operation conditions like vibrations and oscillation movements under high load which are typical for pitch and yaw bearings of wind turbines. It is also used for gear lubrication of pitch and yaw bearings using a lubrication pinion.

- Outstanding wear protection, especially at shock loads and oscillatory movements
- Extremely wide temperature range, suitable for any climate condition: -45°C up to +130°C
- Consistency: NLGI grade 2
- Identification according to DIN 51502: KPFHC2K-40
- Excellent protection against false brinelling and fretting corrosion
- Extreme pressure properties at low rotational speed
- Pumpable in automatic lubrication systems
- Approvals: Rothe Erde (ThyssenKrupp), IMO, ZS Schmieranlagen
- References: manufacturers and operators of wind power plants and component manufacturers

High-performance grease for main bearings, pitch and yaw bearings

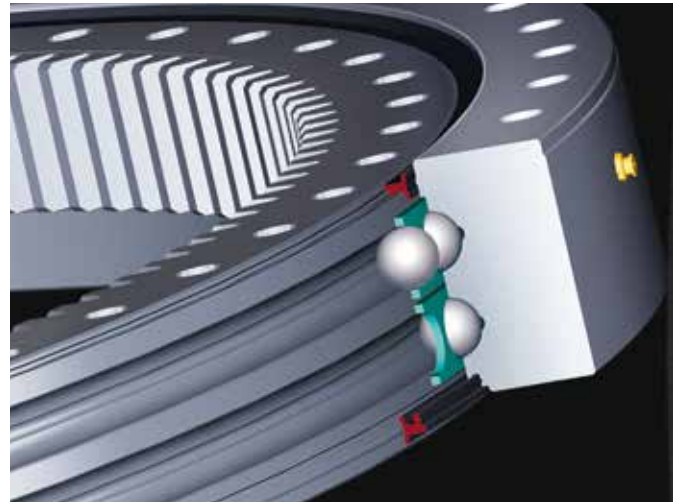

Photo: Rothe Erde

STABYL EOS E 2

STABYL EOS E 2 is a high-performance grease based on a fully-synthetic ester and a lithium soap. It fulfils the highest technical requirements for modern lubricants used in wind turbines. STABYL EOS E 2 was developed as multi-function grease in a perennial research project in cooperation with leading bearing manufacturers and is successfully in use in wind turbines as general purpose lubricant.

- Universal application in wind turbines, especially for pitch, yaw and rotor bearings
- Extremely wide temperature range, suitable for any climate condition: -45°C up to +130°C
- Consistency: NLGI grade 1-2
- Identification according to DIN 51502: KPE1-2K-40
- Allows considerable reduction of lubricant diversity on wind turbines
- Very good protection against false brinelling and fretting corrosion
- Extreme pressure properties at low rotational speed
- Pumpable in automatic lubrication systems
- Approvals: Rothe Erde (ThyssenKrupp), IMO, ZS Schmieranlagen
- References: manufacturers and operators of wind power plants and component manufacturers

Fully synthetic high-performance grease for pitch, yaw and rotor bearings



STABYL LX 460 SYN

STABYL LX 460 SYN is a fully synthetic high-performance grease which was especially developed for the use in wind turbines. Due to its wide operating temperature range, its high mechanical stability and its outstanding load carrying capacity, STABYL LX 460 SYN is excellently suitable for the lubrication of the main rotor bearings. Moreover, it can also be used as multifunctional grease in the very demanding lubricating areas of azimuth and pitch bearings because of its special properties. Therefore STABYL LX 460 SYN considerably reduces the necessary efforts for a safe grease supply in all these lubricating points.

- Universal application in wind turbines, especially for pitch, yaw and rotor bearings
- Extremely wide temperature range, from -40°C up to $+140^{\circ}\text{C}$
- Consistency: NLGI grade 1-2
- Identification according to DIN 51502: KPHC1-2N-40
- Reduction of lubricant diversity in wind turbines
- Excellent protection against false brinelling and fretting corrosion
- Pumpable in automatic lubrication systems
- Extreme pressure properties to protect against wear

White adhesive lubricant suitable for low temperatures

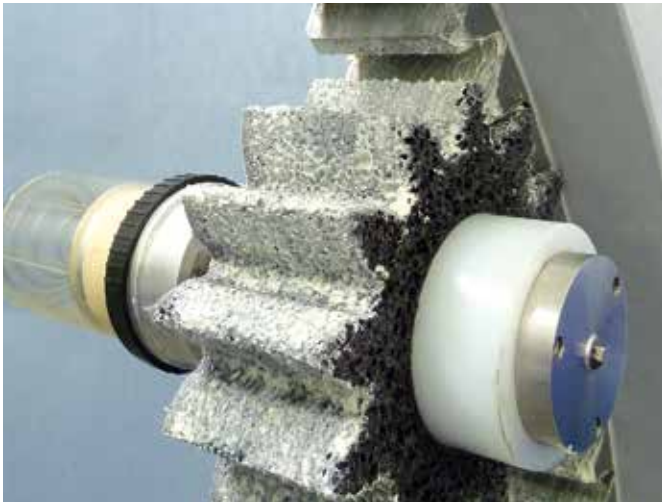

Photo: ZS Schmieranlagen

CEPLATTYN BL WHITE

CEPLATTYN BL WHITE is a white adhesive lubricant with reactive solid lubricants. It is used as a lubricant for machines and machine components operating under difficult conditions, subject to extreme temperature fluctuations and environmental influences. CEPLATTYN BL WHITE is used in particular for the lubrication of azimuth and pitch gear rings in wind turbines.

- For lubricating of azimuth and pitch gears
- Very wide temperature range: -40°C / $+160^{\circ}\text{C}$, up to $+180^{\circ}\text{C}$ for a short time, pumpable down to -30°C
- Very good adhesion to the tooth flanks
- High thermal and mechanical stability
- Protects the gear ring against corrosion
- Very good water resistance, thus also unlimited suitability for off-shore turbines
- Pumpable in automatic lubrication systems
- References: manufacturers of slewing bearings and manufacturers of lubricating equipment

Fully synthetic polyurea grease for extreme application conditions



URETHYN XHD 2

URETHYN XHD 2 is a soft lubricating with on a synthetic hydrocarbon base oil and a very temperature-resistant polyurea thickener. A selected additive package provides excellent wear protection, even at fluctuating speeds, temperatures and loads.

- High-temperature lubricant for long-life lubrication of roller bearings at high temperatures, high loads, and speeds e.g. in generator bearings of wind turbines
- Temperature range: -40°C up to $+180^{\circ}\text{C}$, short-term up to $+200^{\circ}\text{C}$
- Consistency: NLGI grade 2
- Identification according to DIN 51502: KPFHC2R-40
- Extraordinary thermal stability
- High oxidation stability also during intermittent operation
- Pumpable in automatic lubrication systems
- References: manufacturers and operators of wind power plants, components and lubrication system manufacturers

FUCHS SCHMIERSTOFFE – SPECIAL GEAR OILS FOR WIND TURBINES

More and more wind turbine manufacturers and operators have recognized the benefits of synthetic gear oils. With the gear oils in the RENOLIN UNISYN CLP range, FUCHS has been an exponent of these high-grade special oils for the strict requirements of wind energy plants from the very start. With several thousand installations worldwide and many gigawatts of generated energy, we have a great deal of experience in the market with our lubricants.

Polyalphaolefin-based (PAO) fully synthetic circulating and gear oils

RENOLIN UNISYN CLP

The products in the RENOLIN UNISYN CLP range are based on special fully synthetic hydrocarbons/polyalphaolefins. In connection with selected EP/AW additives and additive systems, the products guarantee excellent wear protection characteristics, good corrosion protection, high thermal/oxidative resistance and therefore a long service life. In comparison with mineral oil-based products, a four- to five-fold extension of service life can be achieved using RENOLIN UNISYN CLP.

In testing on test rigs and during wind turbine inspections, use of RENOLIN UNISYN CLP made it possible to lower the oil sump temperature in circulation systems and transmissions by approximately 5 °C to 10 °C in comparison with mineral oil-based products (low gear friction coefficients under load). Besides the reduction in temperature load on oil and components, this leads to an improvement in efficiency of up to 3%. The product has been used highly successfully in wind turbines worldwide for years. With an overall rating of 1.0, RENOLIN UNISYN CLP 320 also delivered impressive results in the FAG 4-stage wind turbine test (Schaeffler Group) in comparison with commonly used competitor products.

It excels through its excellent wear protection characteristics in applications with differing mixed friction conditions, EHD conditions (elastohydrodynamic lubrication) and extremely high loads. Excellent results were even achieved under the influence of water contamination. The micropitting resistance is high, as the gears in the transmission are reliably protected from this phenomenon over a wide temperature range.

- Fully synthetic PAO-based gear oils
- Miscible and compatible with mineral oil and ester oil
- Micropitting resistance "high", failure load stage: LS > 10 at both +60 °C and +90 °C
- FZG scuffing load capacity, high degree of protection, FZG A/8.3/90 failure load stage >14, FZG A/16.6/140, failure load stage >12
- FAG 4-stage wind turbine test, overall rating 1.0 (excellent wear protection characteristics)
- FE 8 roller bearing wear test, 7.5/80/80 and 7.5/100/80: no wear
- WEC test (white etching cracks) as per FE8 pitting test VWPV1483, no WEC damage (high protection)
- Excellent oxidation stability
- Excellent thermal stability – SKF WTGU test passed at +100 °C
- Excellent filterability
- Low foaming tendency
- Excellent air release properties
- Excellent material compatibility
- Approvals and references: Acciona, BOSCH REXROTH, EICKHOFF-SERVICE, ENERCON, SIEMENS FLENDER, GAMESA, GE, HANSEN, JAHNEL+KESTERMANN, LIEBHERR, SIEMENS, WINERGY, ZOLLERN, RENK and other leading gear box and wind turbine manufacturers

Gear oil in wind power plants

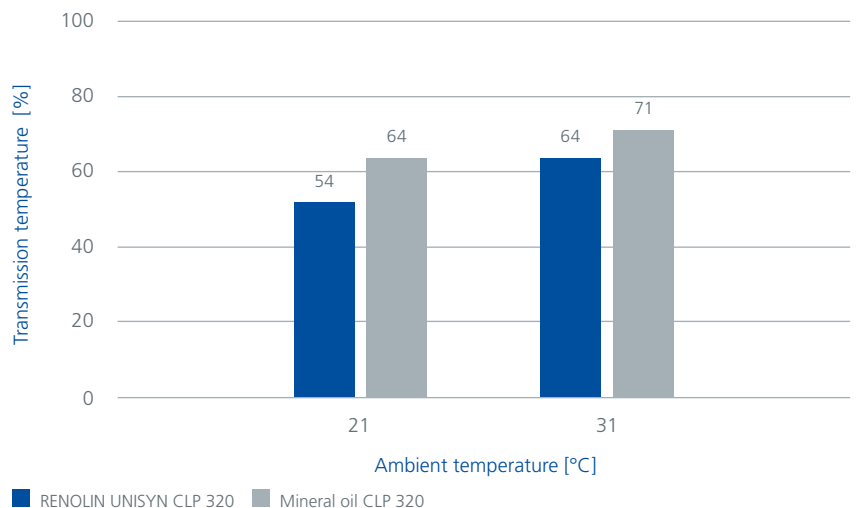

Environmentally friendly circulating and gear oils based on synthetic, fully saturated esters

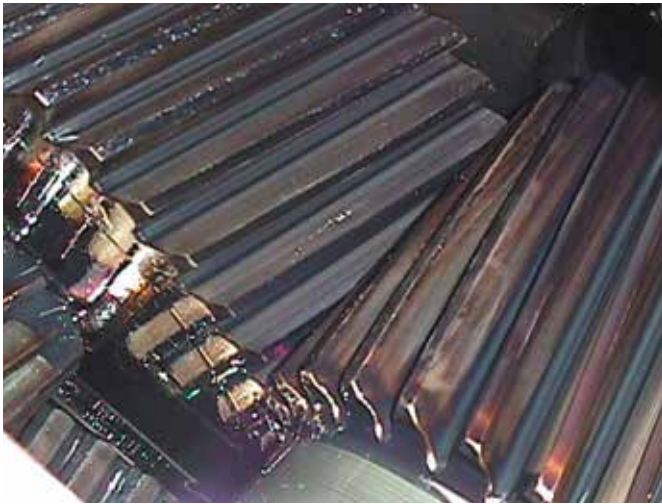

Gear before the change over to GEARMASTER ECO

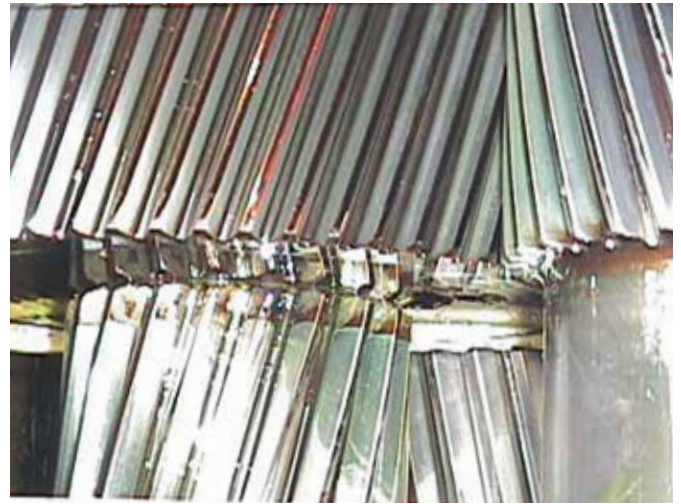

Gear after the change over to GEARMASTER ECO

GEARMASTER ECO

GEARMASTER ECO lubricating oils are environmentally friendly high-performance industrial gear oils based on synthetic, fully saturated esters. Particularly in the field of wind turbines, operators increasingly favour the use of environmentally friendly and resource-saving materials. Using its decades of experience and its position as market leader in the field of biodegradable and biogenic (as per CENTR 16227), FUCHS developed and successfully established a gear oil in the market that meets the strict transmission lubrication requirements of wind turbines, while at the same time protecting the environment (biodegradability >60% as per OECD 301 C) and making a major contribution to resource conservation (the formation is based on a high share of renewable resources).

GEARMASTER ECO gear oils are based on polar synthetic saturated ester oils. Thanks to the raw material selected, they offer a very good wetting capacity and outstanding cleaning properties (Clean Gear Technology).

They excel through their excellent corrosion protection, as well as high temperature and oxidation stability. Low friction coefficients mean that gear oil temperatures can be reduced and efficiency increased. GEARMASTER ECO 320 has been used successfully in wind turbines for years. In the "4-stage test" developed specially for wind turbine applications by FAG (Schaeffler Group), the wear protection characteristics of industrial gear oils are tested in four different load groups (stages). The tests are performed at extreme mixed friction, at moderate mixed friction, with elastohydrodynamic lubrication and with water-contaminated oil.

GEARMASTER ECO 320 performed extremely well in the tests and scored an overall rating of 1.0 (very good). It displays excellent wear protection characteristics for the most diverse of load stages. GEARMASTER ECO also boasts a high scuffing load carrying capacity and high micropitting resistance over a wide temperature range.

Environmentally friendly gear oils

Foaming behavior in the Flender foaming test before and after filtration: very good filterability

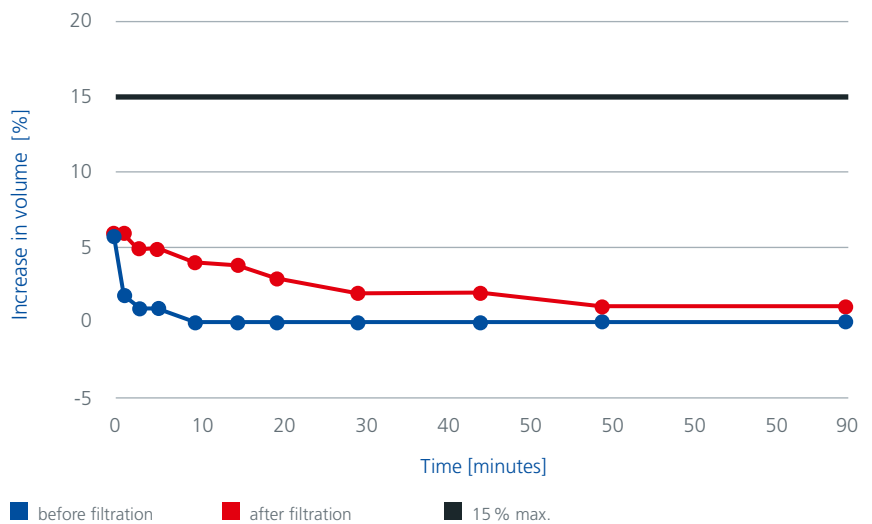

- Fully synthetic, biodegradable lubricants based on fully saturated synthetic esters
- Miscible and compatible with mineral oil and PAO
- Micropitting resistance "high", failure load stage: LS > 10 at both +60 °C and +90 °C
- FZG scuffing load capacity, high degree of protection, FZG A/8.3/ 90, failure load stage >14, FZG A/16.6 / 140, failure load stage >12
- FAG 4-stage wind turbine test, overall rating 1.0 (excellent wear protection characteristics)
- FE 8 roller bearing wear test, 7.5/ 80/80 and 7.5/100/80: no wear

- Excellent oxidation stability
- Excellent thermal stability – SKF WTGU test passed at +100 °C
- High cleaning capacity thanks to Clean Gear Technology
- Excellent filterability
- Low foaming tendency, excellent air release properties
- Excellent material compatibility
- Approvals and references: BOSCH REXROTH, CHONQING CHONGCHI, FLENDER, MOVENTAS, WINERGY (GE) and other leading transmission and wind turbine manufacturers



GEARMASTER ECO 320 has been awarded the EU Ecolabel.

The EU Ecolabel is the official environmental mark of the European Commission and is awarded by the RAL Institute. Requirements of lubricants as per EU Ecolabel 2011/371/EU:

- Biodegradable as per OECD 301 >60 %
- Non-toxic
- Proportion of renewable raw materials >50 %
- Technical requirements of gear oils as per DIN 515173

Fully synthetic circulating and gear oils based on innovative PAO



NEW: RENOLIN UNISYN XT

With the development of the RENOLIN UNISYN XT range, FUCHS created fully synthetic circulating and gear oils based on the latest technology. In the products of the RENOLIN UNISYN XT range, innovative PAO base oils are combined with a special EP/AW additive technology. The use of innovative PAO grades in particular allows the benefits of a much wider operating temperature range compared to conventional PAO-based circulating/gear oils, while also improving low-temperature flow characteristics. They therefore offer significant advantages in terms of starting behavior at low temperatures when compared with conventional PAO grades.

The products in the RENOLIN UNISYN XT range boast a high natural and shear-resistant viscosity index of around 180. In addition to this, the RENOLIN UNISYN XT oils offer increased aging stability, good load-carrying capacity and reliable wear protection for roller bearings and gears in wind turbine transmissions. Thanks to their high micropitting resistance, they offer reliable protection from this phenomenon over a wide temperature range.

RENOLIN UNISYN XT 320 has been tested in the FAG 4-stage wind turbine test (Schaeffler Group) and has shown excellent results with an overall rating of 1.0.

- Fully synthetic gear oils based on innovative PAO
- Miscible and compatible with mineral oil, ester oil and conventional PAO gear oils
- Micropitting resistance „high“, reliable protection
- Micropitting, failure load stage: LS > 10 at both 60 °C and 90 °C
- FZG scuffing load capacity, high degree of protection, FZG A/8.3/90, failure load stage >14, FZG A/16.6/90, failure load stage >14
- FAG 4-stage wind turbine test, overall rating 1.0 (excellent wear protection characteristics)
- FE 8 roller bearing wear test 7.5/80/80: roller bearing wear 1.0 mg, 7.5/100/80: roller bearing wear 7 mg (excellent wear protection characteristics)
- WEC test (white etching cracks) as per FE 8 pitting test VW-PV-1483, no WEC damage (high degree of protection)
- Excellent low-temperature behavior
- Low foaming tendency
- Good air release properties
- Very good aging stability

RENOLIN UNISYN XT has a better start-up behavior and cold flow properxes due to excellent low temperature viscosities

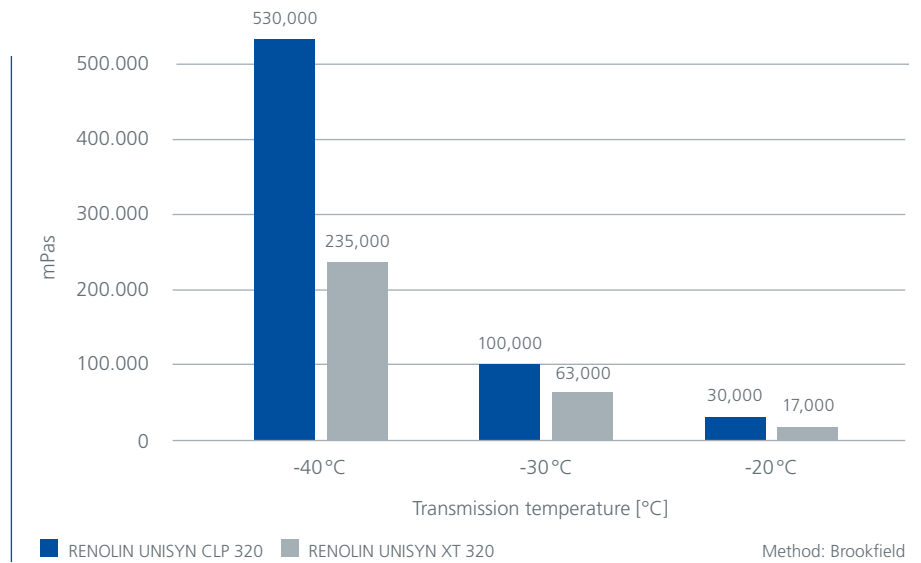

- Very good corrosion protection
- Excellent viscosity-temperature behavior
- Very high natural shear-resistant viscosity index (VI around 180)
- Multigrade characteristics
- Excellent wear protection, high scuffing load carrying capacity
- For high-temperature and low-temperature applications
- RENOLIN UNISYN XT is approved by SIEMENS FLENDER, BOCHOLT, table A 7300

At operation temperatures RENOLIN UNISYN XT shows a better stability of the lubrication film

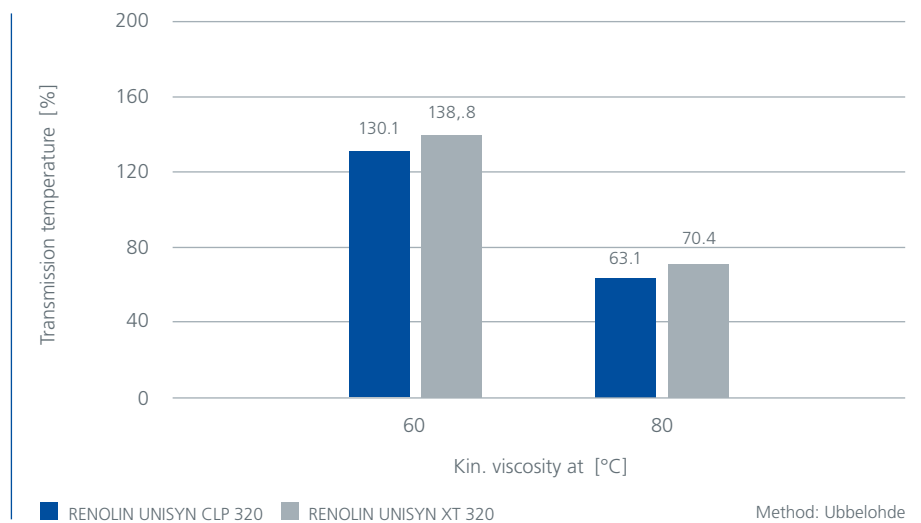

PAO-free high-performance gear oil based on innovative base oil technology for gears / roller bearings



RENOLIN PentoGear 320 WT

With RENOLIN PentoGear 320 WT, FUCHS developed a PAO-free wind turbine gear oil with innovative base oil technology. RENOLIN PentoGear 320 WT is formulated by the use of special polymers and hydrated base oils. Its use as a high-performance gear oil is recommended for all wind turbine installations, particularly in the service segment. In developing RENOLIN PentoGear 320 WT, a major focus was on good miscibility with the industrial gear oils commonly used in the market. The use of innovative base oils, together with a matched additive system, allows excellent performance to be achieved.

RENOLIN PentoGear 320 WT displays excellent wear protection, both for gears and roller bearings. In addition to this, RENOLIN PentoGear 320 WT displays good corrosion protection (steel and copper) and good compatibility with the seals and coatings used in wind turbines. Field tests have demonstrated that the product is capable of reducing the oil temperature in heavy duty bearings.

In real-world applications, RENOLIN PentoGear 320 WT was able to demonstrate its robust operating performance, excellent foaming behavior and very low deposit formation.

- PAO-free gear oil, based on innovative base oils, which delivers very good technical performance
- Miscible and compatible with mineral oil, PAO oil and ester oil
- Micropitting resistance "high", failure load stage: LS >10 at both 60°C and 90°C
- FZG scuffing load capacity, high degree of protection
- FZG A/8.3/90, failure load stage >14
- FZG A/16.6/90, failure load stage >12
- FE 8 roller bearing wear test 7.5/8/80: roller bearing wear 3 mg (very good wear protection characteristics)
- Good miscibility/compatibility with mineral oil-based and PAO-based industrial gear oils
- Good compatibility with seals and coatings
- Lowest deposit formation, robust operating performance
- Good foaming behavior
- Combination of polar and non-polar base oil components, „low varnish oil“
- RENOLIN PentoGear 320 WT is approved by SIEMENS FLENDER, BOCHOLT, table A 7300

Further specialties for power transmission engineering applications



RENOLIN MR 90 – Special oil

Special run-in, preserving and test rig gear oil. Excellent cleaning effect, high degree of corrosion protection, very good wear protection capacity.

RENOLIN GEAR VCI and RENOIN UNISYN GEAR VCI – gear oils

Gear oils with excellent anticorrosive properties. They are formulated on the basis of selected mineral oils/PAO base oils with specially developed VCI components (volatile corrosion inhibitors) for safe storage and transport of machines and components. Machine elements and transmissions are reliably protected from corrosion also in air/steam areas (non-wetted surfaces).

RENOLIN HighGear – synthetic gear oil

Polyalphaolefin-based (PAO) industrial gear oils employing the latest additive technology with plastic deformation (PD) additive technology. For pre-damaged machine elements and “critical applications”.



RESEARCH AND DEVELOPMENT FOR PERFECT PERFORMANCE

Technologically advanced, process-oriented and holistic lubricant solutions are a central success factor for FUCHS. Our worldwide network of experts meets customer requirements on a global level by quickly and efficiently networking fields of special expertise. Around one in ten employees works in R&D. The company currently has more than 600 ongoing research and development projects that aim to provide optimum answers to the requirements of our customers.

This allows us to defend and consolidate our technological leadership in important business segments. This is not only a question of effectiveness and efficiency or safety and reliability, but also of the sustainability of the lubricants – from production, right through to disposal.

White etching cracks

New mechanical tests for industrial gear oils

WEC – white etching cracks

Over the last few months and years, there have been more and more discussions on failures of roller bearings, gear teeth and gear boxes as a result of the damage phenomenon known in the market as “white etching cracks”.

The damage observed led to this question:

to what extent do certain additives and gear oil formulations prevent or promote white etching cracks in roller bearings and gears?

This in turn led to the development of a roller bearing bench test, as these machine elements are particularly susceptible to the WEC phenomenon. The FE8 pitting test as per VW-PV-1483 was used to investigate WEC. The test was performed on axial cylinder roller bearings with an axial load of 60 kN at speeds of 350 and 750 rpm, at an oil temperature of 100 °C and an oil flow rate of 2 x 0.1 l/min.

The fatigue life of the bearing and the influence of the oil formula are determined and the occurrence of the WEC damage on the cylinder raceway or cylinder roller is evaluated.

An API GL4 manual transmission oil was defined as the low reference oil and used to generate WEC damage on the roller bearing raceway.



Among others, RENOLIN UNISYN CLP and RENOLIN UNISYN XT were used as high reference oil. With the RENOLIN UNISYN CLP 100 and RENOLIN UNISYN XT 100 high reference industrial gear oils, a test aviation of > 9 million revolutions was reached in this roller bearing test without any WEC-type damage occurring.

RENOLIN gear oil formulations were also tested in combination with various anticorrosion oils, metal working fluids and critical additive components. The robustness of the formulation displays excellent wear protection characteristics and optimum protection with regard to the white etching cracks phenomenon.

Note

The information contained in this product information is based on the experience and know-how of FUCHS SCHMIERSTOFFE GMBH in the development and manufacturing of lubricants and represents the current state-of-the-art. The performance of our products can be influenced by a series of factors, especially the specific use, the method of application, the operational environment, component pre-treatment, possible external contamination, etc. For this reason, universally-valid statements about the function of our products are not possible. Our products must not be used in aircrafts/spacecrafts or their components, unless such products are removed before the components are assembled into the aircraft / spacecraft. The information given in this product information represents general, non-binding guidelines. No warranty expressed or implied is given concerning the properties of the product or its suitability for any given application.

We therefore recommend that you consult a FUCHS SCHMIERSTOFFE GMBH application engineer to discuss application conditions and the performance criteria of the products before the product is used. It is the responsibility of the user to test the functional suitability of the product and to use it with the corresponding care.

Our products undergo continuous improvement. We therefore retain the right to change our product program, the products, and their manufacturing processes as well as all details of our product information sheets at any time and without warning, unless otherwise provided in customer-specific agreements. With the publication of this product information, all previous editions cease to be valid.

Any form of reproduction requires express prior written permission from FUCHS SCHMIERSTOFFE GMBH. Stand 08/2016

Reliability and service life

FE 8-roller bearing wear test rig



Special hydraulic fluids for wind power applications

ECO HYD S PLUS

Special hydraulic fluids for wind turbines.

Rapidly biodegradable high-performance hydraulic oil and lubricating oil based on fully saturated synthetic esters. Multigrade characteristic thanks to excellent viscosity-temperature behavior (high natural shear-resistant viscosity index, VI >150). Excellent low-temperature properties, good lubricant film stability, high degree of wear protection (failure load stage >12, FZG A/8.3/90), rapidly biodegradable (>60 % as per OECD 301C). The change over guidelines acc. to ISO 15380 must be observed.

RENOLIN HVI 32 GA

Special multigrade hydraulic oil based on mineral oil.

RENOLIN HVI 32 GA is a multigrade hydraulic oil for a wide operating temperature range that was developed using special base oils.

RENOLIN HVI 32 GA has a high, shear-resistant viscosity index, VI >160. The flat curve of the viscosity-temperature characteristic guarantees good low-temperature flowability and high lubricant film stability. RENOLIN HVI 32 GA guarantees a high degree of wear protection, high stability and good corrosion protection.

Vickers pump test

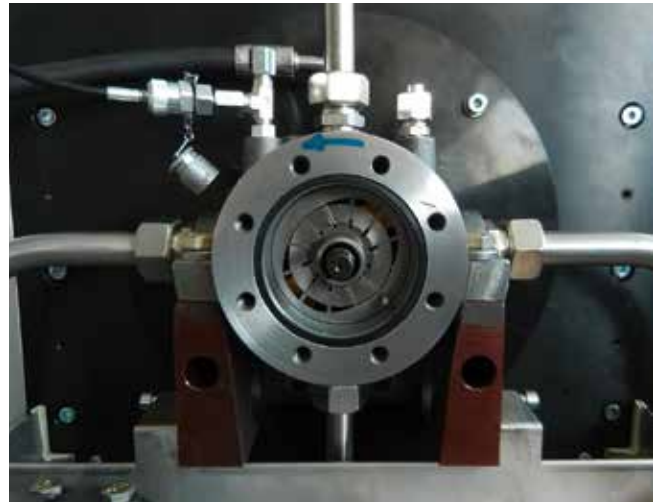

Other multigrade hydraulic oils

RENOLIN UNISYN OL 32, 46

Fully synthetic hydraulic fluids based on synthetic hydrocarbons – polyalphaolefins (PAO).

These fluids boast excellent low-temperature properties (pour point <60 °C) and very good air release properties (air release = 2 mins). For extreme temperature requirements. Long lifetime.

RENOLIN XtremeTemp 32, 46

Partially synthetic hydraulic fluids based on hydrogenated hydrocarbons.

RENOLIN XtremeTemp boasts excellent low-temperature-properties (kin. viscosity at -20 °C VG 46: 2,040 mm²/s), high shear stability, excellent wear protection and a very long service life at high pressures and a high circulation index.

RENOLIN ZAF 32 LT

Zinc-free and ash-free mineral oil-based hydraulic oil with very high viscosity index, VI >280.

Excellent low-temperature behavior (pour point <-60 °C) and thereby very wide operating temperature range. New zinc- and ash-free additive technology.

Excellent wear protection

RENOLIN UNISYN CLP 320: FAG 4-stage test

Oil: FUCHS RENOLIN UNISYN CLP 320
tested as VP LA_4_05_005 Var. 6.1

Supplier: FUCHS

Oil type: PAO

	Criterion	Test		Result
STAGE 1*	wear at boundary lubrication	FEB-80h	1,0	passed
STAGE 2**	fatigue beh. at mixed friction cond.	FEB-80h	1,0	passed
STAGE 3***	fatigue behaviour at EHL-cond.	L11-700h	1,0	passed
STAGE 4***	running time 600 hours	FEB-WKA	1,0	passed
	summary	1,0	passed	

	Result	1	2	3	4	5	Test	Result	Rating	
STAGE 1*	wear of rollers V50WK	< 10	< 15	< 20	< 30	< 30	yes	0	1	
	rippings	no	–	small	ro or wash	ro + wash	yes	no	1	
	micro pittings	no	–	–	no	strong	yes	no	1	
								stage 1	1,0	passed
STAGE 2**	running time (hours)	> = 800	–	–	–	< 800	yes	800	1	
	wear of rollers V50WK	< 10	< 15	< 20	< 30	< 30	yes	2	1	
								stage 2	1,0	passed
STAGE 3***	no fatigue damage forced by additives up to L50 (hours)	700	650	600	550		yes	700	1,0	passed
STAGE 4***	running time 600 hours	> = 600	–	–	–	< 600	yes	600	1	
	filter blocking	no	–	–	–	–	yes	no	1	
	wear of rollers V50WK	< 10	–	–	–	–	yes	0	1	
	wear of cage V50KF	< 20	–	–	–	–	yes	84	no	
	fatigue damages	no	–	–	–	–	yes	no	1	
	residues at the bearing	slight	sl/mod	moderate	mod/heavy	heavy	yes	slight	1	
	residues at the preheating system	slight	sl/mod	moderate	mod/heavy	heavy	yes	slight	1	
									stage 4	1,0
	summary	1,0	passed							

* Tested by FUCHS report PFMA-06-0110 (unknown batch number)

** Tested by Assmann report 4206b - batch V6.2

*** Step 3 and 4 tested by Schaeffler KG

Special lubricants for wind power plants

FUCHS a comprehensive service provider to the wind power industry

- Individual selection and evaluation of lubricants based on lubricant recommendations and analyses.
- Full documentation with gearbox-condition reports and recommendations.
- Reliable gear oil reports with high-accuracy oil analyses which provide specific details about oil condition and allow oil change intervals to be scheduled exactly.
- Experts support your evaluation of grease analyses out of pitch-, yaw-, main- and generator bearings.

Contact:

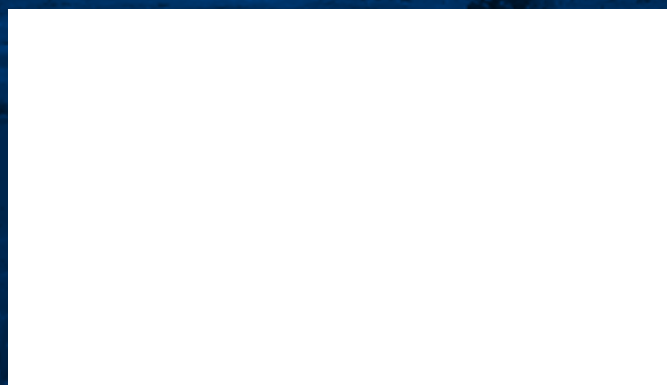

FUCHS SCHMIERSTOFFE GMBH
Friesenheimer Straße 19
68169 Mannheim/Germany
Phone: +49 621 3701-0
Fax: +49 621 3701-570
E-mail: zentrale@fuchs-schmierstoffe.de
www.fuchs.com/de/en

FUCHS LUBRITECH GMBH
Werner-Heisenberg-Straße 1
67661 Kaiserslautern/Germany
Phone: +49 6301 3206-0
Fax: +49 6301 3206-940
E-mail: info@fuchs-lubritech.de
www.fuchs-lubritech.com